

Gas Detection System

GMC Ecoline 8304
GM Ecoline HC50

approved to
EN 50194



Operating and Installation Instructions

Gas Detection and Warning Systems



Contents

Important Instructions

Instructions Relating to these Operating and Installation Instructions	3
------------------------------------------------------------------------	-------	---

Application, Operation

Functions of GMC Ecoline 8304	4
Behaviour when an Alarm is Given	5
Instructions for Users	6
Display and Control Elements	6

Installation and Connection

General Instructions for Installing, Connecting and Commissioning the Gas Detection System	8
Installing the GMC Ecoline 8304	8
Installing the GMC Ecoline HC50	9
Connecting the GMC Ecoline 8304	10
Connecting the GMC Ecoline HC50	13
Setting the GMC Ecoline 8304	14
Final Steps in Installation	15
Commissioning	16

Maintenance, Adjustment and Care

General Instructions for Maintenance, Adjustment and Care of the Gas Detection System	16
Adjusting the GMC Ecoline HC50	17
Replacing GMC Ecoline HC50 Sensors	18
Overview of Fault Messages	19
Replacement Parts	19
Cleaning	19

Technical Information

Technical Data	20
Mechanical Data	21
Appendix: Adjustment Report GM Ecoline HC50	22
Accessories	24
Guarantee	24

**Instructions Relating to these Operating and Installation Instructions**

Failure to observe this sign can

- have serious consequences for persons
- lead to faulty operation of the gas detection system.

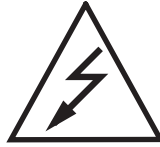

Danger arising from electrical voltage at electric components.
When the plant is switched on, never touch electric components or contacts.
Danger of electric shock which could result in serious injury or death.



Electrostatically sensitive components! Contact with these parts could damage or destroy them.
Avoid touching them!
Grasp PCBs only on their edges.
Before starting work, ensure that you are electrostatically discharged by touching earthed metal parts.

Declaration of Conformity

A declaration of conformity is available for inspection.

Safety

- Install and operate the equipment in accordance with these operating instructions.
- Observe the relevant safety regulations.

Personnel

Installation, configuration and servicing of the equipment should only be carried out by qualified, specialist personnel.

Further Information

Due to the continual development of the product, it is possible for the operating instructions to be changed without prior notice. Bieler + Lang will be pleased to provide further information or answer any questions you may have.

Functions of GMC Ecoline 8304

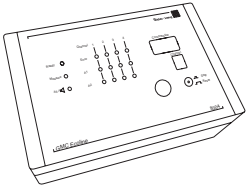

The system is designed to reliably detect natural gas and LPG. Up to four hazard zones can be monitored. When an alarm situation arises, the controller switches the technical safety measures at relay contacts and closes a connected solenoid valve in the gas supply line. A buzzer in the controller gives an acoustic alarm.

Four DC switches (nominal voltage 32 VDC/ 200 mA) are incorporated which can be used for further switching tasks.

The Ready LED signals that the system is ready for use. The Measure LED indicates each measurement. For each measurement channel, there are optical signals for faults, pre-alarm and main alarm. A fault (Error LED) is indicated when the measurement range is undershot or exceeded. A wire breakage in the sensor line is also indicated here. The LEDs A1 and A2 signal that a pre-alarm or a main alarm has been triggered. The current measurement reading is shown in the display. The channel number assigns a reading to the appropriate measurement channel. By briefly pressing the STOP button of a channel, the reading of that channel can be displayed continuously. When the main alarm threshold is exceeded, the integral buzzer sounds. This can be turned off by holding the RESET button pressed for a longer period.

There are four output relays (230VAC/4A) for connecting further technical equipment and signalling devices:

- Relay for pre-alarm
- Relay for main alarm
- Relay for acoustic warning devices
- Relay for fault messages

These signals take the form of a collective alarm. This means that all four measuring points send their signals to the same relay.

There are further integral DC switches for sending these signals to other systems in the building for further processing. These can be used for any of the following functions as required:

- DC switch for collective alarm: pre-alarm, main alarm, horn, fault
- DC switch for individual alarm 1: 4x individual pre-alarms
- DC switch for individual alarm 2: 4x individual main alarms

The alarm signal „main alarm“ has an alarm memory. This means that following an alarm, the alarm LEDs and the relay outputs assigned to them continue to indicate an alarm. This condition can be cancelled by pressing the RESET button. If required, the pre-alarm can also be equipped with this function. The alarm is set to the following thresholds:

- pre-alarm 10 %LEL, main alarm 20 %LEL

In addition, the alarm thresholds can be provided with a 30-second switch-on delay. This is indicated by the relevant alarm LED blinking until the delay time has expired.



Behaviour when an Alarm is Given



It is recommended that the following instructions are observed both when an alarm occurs, and when there is a smell of gas without an alarm being given:

Keep calm and take the following measures (not necessarily in the order given here):

- extinguish all naked lights, cigarettes, cigars, pipes etc.;
- turn off all gas appliances;
- do not switch any electrical equipment (including the gas detector) on or off;
- turn off the gas supply at the main shut-off valve and/or (for liquefied gas) at the storage tank;
- open doors and windows to increase ventilation;
- do not use a telephone in the building in which the presence of gas is suspected.

If the alarm continues, where relevant after resetting the alarm, and the cause of leakage is not evident, clear the building and **IMMEDIATELY INFORM** the gas supplier and/or the 24-hour gas emergency service, so that the gas installation can be checked, made safe, and all necessary repairs carried out.

If the alarm stops or a latched alarm has been reset in accordance with the manufacturer's instructions, and the cause of the alarm has been determined (for example a gas tap open and the burner not alight) and corrected, the main gas supply can be turned on again once the release of gas has been stopped and it is certain that all appliances are turned off.

This system can be set so that there is a delay of 30 seconds between the acoustic alarm and the output signal being switched. However, even when the system includes a switching device, for example a solenoid valve in the gas supply line, the procedure described above should still be followed completely.



Always take the above measures if you smell gas before an alarm has been triggered.



Instructions for Users



- Making unauthorised changes to the equipment and improper use can cause electric shocks.
- Never open the controller..
- In the event of damage to the housing or the installed wiring, take the unit out of service by switching off the power supply.



- Never check that the system functions by using a gas lighter, a spray can, or inflammable vapours generated from paints or solvents.
- The system must be adjusted at least once a year by a specialist authorised by Bieler + Lang.
- The working life of a thermal-effect sensor can be reduced by what are known as catalyst poisons. Such substances are compounds of sulphur, phosphorus, silicon, and lead. Corrosive substances, which may be formed by the reaction of fluorine and chlorine compounds, will reduce the anticipated working life of > 3 years.
- Clean the unit with a damp cloth only externally. Do not use a cleaning agent.

Display and Control Elements

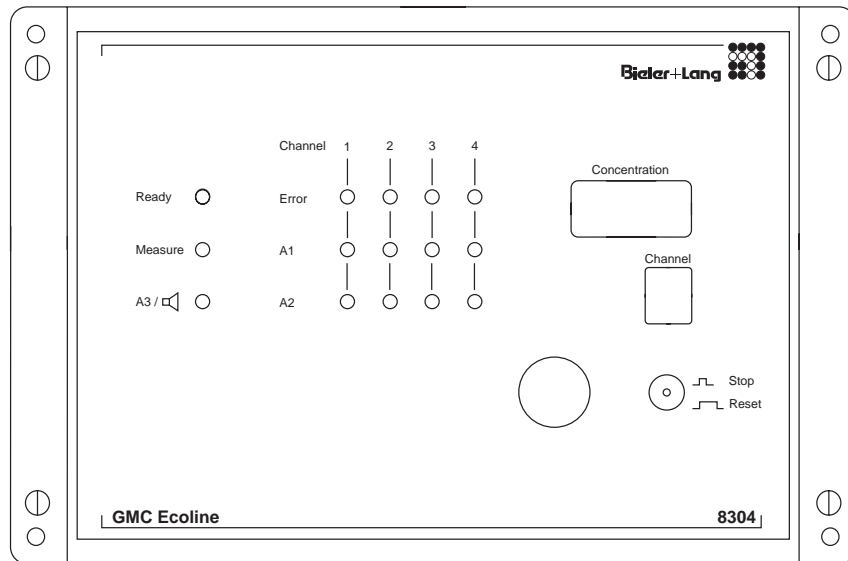
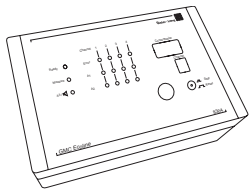

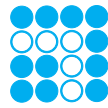

Display and Control Elements

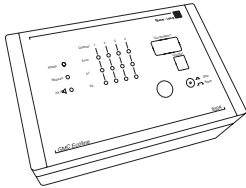

Ready	Light on - green	System ready for use, power supply OK
Measure	Blinks green	Detector signals read
Error	Light on - yellow	Fault at appropriate detector input: signal outside measurement range, wire breakage, short circuit, no sensor connected
Concentration / Channel		Display of current reading of sensor for channel indicated in display
Stop / Reset		<p>Stop: Press the button briefly (< 1 s). The display "Concentration" shows continuously the reading on the field channel indicated.</p> <p>Important: Alarm monitoring of the other detectors connected is not affected by this operation. By pressing the button briefly again, all channels will be shown again in sequence.</p> <p>Reset: Press the button for a longer period (> 1 s). Reset the horn/A3. Reset alarm stages 1 and 2</p> <p>Important: While alarm threshold 2 is exceeded, output A3/Horn can be acknowledged. Alarms 1 and 2 can only be acknowledged when the concentration has fallen below the threshold.</p>
A1	Light on - red	Alarm threshold 1 (pre-alarm) of the appropriate detector is exceeded, relay output switched.
A1	Blinks red	Alarm threshold 1 (pre-alarm) of the appropriate detector is exceeded, but the alarm delay time has not yet expired. After expiry of the delay time, the LED illuminates red and the output relays switch to alarm status.
A2	Light on - red	Alarm threshold 2 (main alarm) of the appropriate detector is exceeded, relay output switched.
A2	Blinks red	Alarm threshold 2 (main alarm) of the appropriate detector is exceeded, but the alarm delay time has not yet expired. After expiry of the delay time, the LED illuminates red and the output relays switch to alarm status.
A3	Light on - red	Alarm threshold 2 (main alarm) of a detector is exceeded and the separate relay output for the horn is switched.
A3	Blinks red	Alarm threshold 2 (main alarm) of a detector is exceeded, but the alarm delay time has not yet expired. After expiry of the delay time, the LED illuminates red and the separate relay output for the horn is switched.



General Instructions for Installing, Connecting and Commissioning the Gas Detection System



- Competent installation and commissioning by qualified personnel (e.g. a qualified electrician) as called for in these installation instructions.
- The installation and electrical connections must comply with the current national regulations of the country in which the system is installed.
- The gas installation and, where relevant, the cut-off device must comply with the current national regulations of the country in which the system is installed.
- The unit must only be operated within the limits given in the technical data. In particular, attention must be paid to the operating temperature, the ambient humidity, and the electrical connection data.
- The gas detection system must not be installed out of doors.

Installing GMC Ecoline 8304

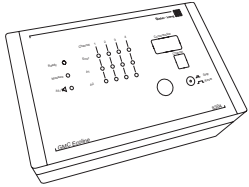

- Take precautions to prevent flooding with water, oil etc., and protect from dust and mechanical damage.
- Install only outside zones in which there is an explosion hazard.
- Install at a location with low levels of vibration and, as far as possible, a stable temperature.
- Ensure that there is access to the system for servicing.

Location Preparation for Installation

- Remove the two blue decorative strips on the right and left of the housing cover. On the sides, at the ends, there are shallow recesses. Insert the blade of a screwdriver in one of the recesses. Apply light pressure to remove the decorative strip; do this on both sides.
- Remove the four screws holding the cover.
- Carefully remove the cover.
- Now disconnect the flat cable from the PCB in the floor pan. To do this you must move the latch lever on the side of the connector to the outside. Pull the connector gently at the same time to disconnect it.
- The floor pan can now be mounted using the fasteners supplied.

Drilling Dimensions

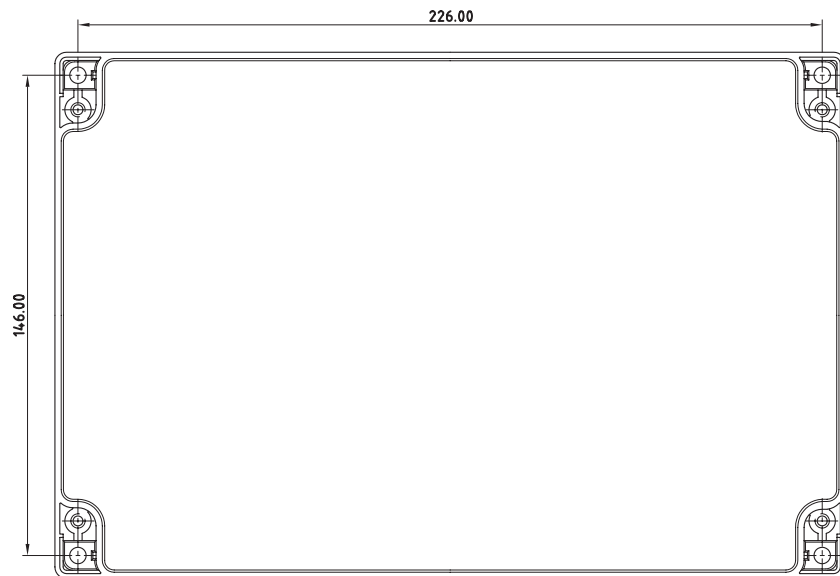



Installing GM Ecoline HC50

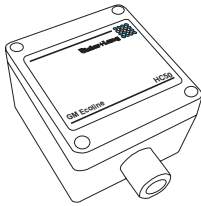

Location

- Take precautions to prevent flooding with water, oil etc., and protect from dust and mechanical damage.
- Install at a location with low levels of vibration and, as far as possible, a stable temperature.
- Ensure that there is access to the system for servicing.
- **Monitoring for natural gas:**
Install at the highest point in the room, directly above a potential leakage point (burner, water heater, gas meter, solenoid valve, ...)
- **Monitoring for LPG:**
Install at the lowest point in the room, directly below a potential leakage point (burner, water heater, gas meter, solenoid valve, ...)

Never install a detector:

- directly above a cooking hob
- directly above a drain
- near a fume-extraction hood
- out of doors
- in a location at which the ambient conditions are outside the limits given in the product specification.

• Maximum cable length

The maximum length of cable between the GMC Ecoline 8304 controller and a detector must not exceed 500 m.

• Cable runs

Plan cable runs so that they are not in the immediate vicinity of sources of electromagnetic interference. The limits specified in standards relevant for the CE mark can only be guaranteed if the system is used properly and installed so as to comply with EMC requirements.

Installation

The detector can now be mounted using the fasteners supplied.

- When mounting on a wall, the cylindrical sensing element must point downwards and thus the cable will enter from the top.
- The cylindrical sensing element must remain accessible for adjustment (ca. 10 cm access space)

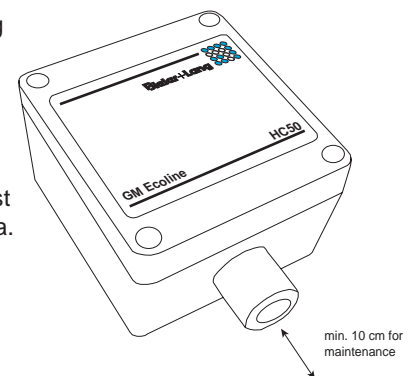



Connecting the GMC Ecoline 8304

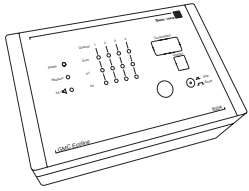

Warning: mains voltage! Before starting work, make sure all electric cables are disconnected from the power supply.

Alarm Output Connections

Remove the insulation panel from the floor tray. It must be replaced when the connections have been made.

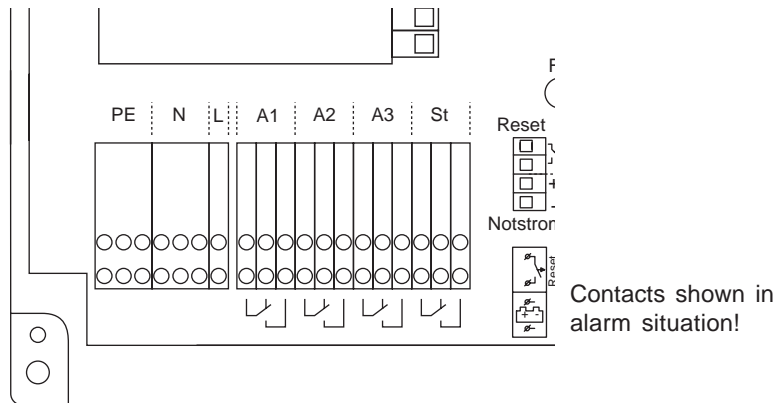

- **Terminals PE / N / L**

Power supply 230 VAC. Use the cable gland provided. Make sure there is adequate strain relief by tightening the gland properly.



As a safety cut-out, install a 6 A circuit breaker in the supply line to the system! (See typical circuit)

- **Terminals A1**

Switch contacts: Alarm 1 / pre-alarm (max 230VAC, 4A)

- **Terminals A2**

Switch contacts: Alarm 2 / main alarm (max 230VAC, 4A)

- **Terminals A3/horn**

Switch contacts: external horn (max 230VAC, 4A)

- **Terminals St/Fault**

Switch contacts: controller and sensor faults (max 230VAC, 4A)

Instructions for connecting cables

- Passing cables through support diaphragms: Make a hole in the diaphragm with a Philips screwdriver. Pass an adequate length of cable through the hole. For optimum sealing, pull the cable back about 10 mm to form a collar which presses tightly round it.
- Remove about 6 to 7 mm of the insulation of the individual leads.
- Insert the blade of a small screwdriver in the rectangular opening of the appropriate terminal. Tilt the screwdriver handle gently upwards to open the terminal.
- Push the stripped end of the correct lead into the terminal. Release the screwdriver to clamp the wire.
- Now pull gently on the lead to make sure it is securely clamped.
- Ensure that there is no uninsulated part of the lead projecting from the terminal.
- Use only leads up to 1.5 mm² maximum cross-section.



Connecting the GMC Ecoline 8304

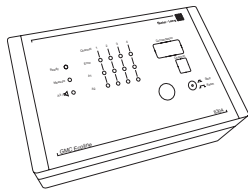

Typical Circuit

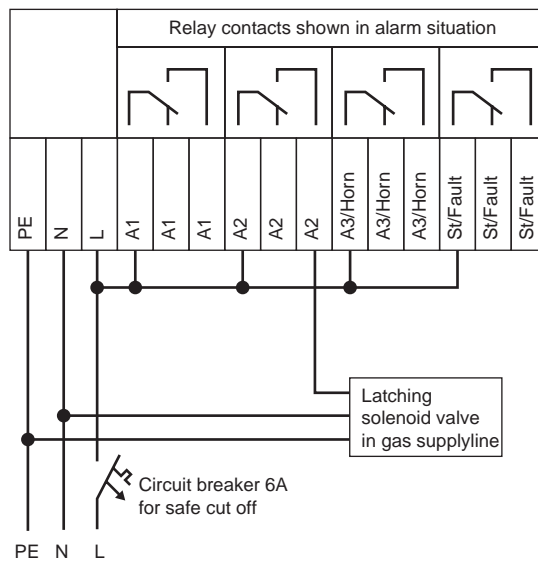

Options

- External Reset
- Emergency Power Supply

As an option, the unit can be supplied to operate on a 24 VDC power supply. The power supply must comply with the requirements stated in the technical data. Fuse F5 (1 A/T) protects the unit. When connecting the unit, make sure the polarity is correct.

A further option permits remote control of the RESET function. In this case, a button with normally-open contacts must be connected at the external RESET input.

Warning: do not connect an external power supply here!

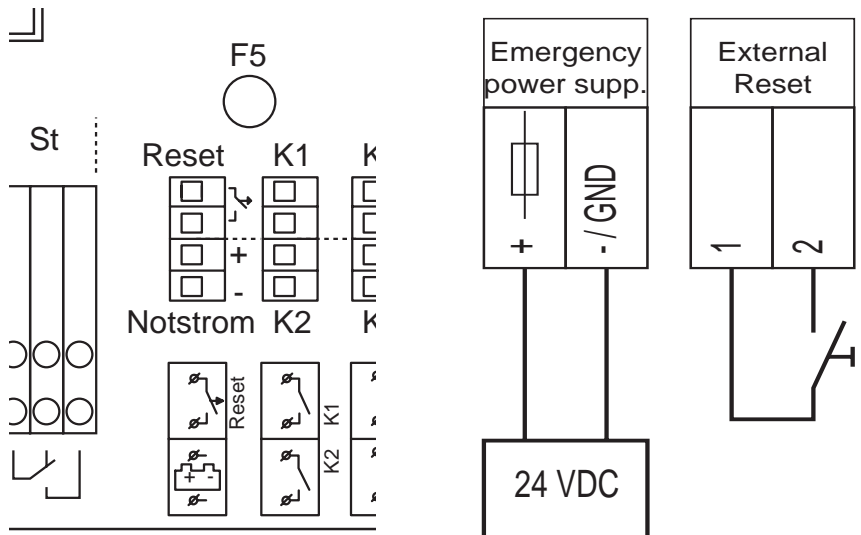

Instructions for connecting cables

- Passing cables through support diaphragms: Make a hole in the diaphragm with a Philips screwdriver. Pass an adequate length of cable through the hole. For optimum sealing, pull the cable back about 10 mm to form a collar which presses tightly round it.
- Remove about 8 mm of the insulation of the individual leads.
- Place the blade of a small screwdriver on the white release button of the appropriate terminal. Pressing lightly on the screwdriver will open the round terminal beside it.
- Push the stripped end of the correct lead into the terminal. Release pressure on the screwdriver to clamp the wire.
- Now pull gently on the lead to make sure it is securely clamped.
- Ensure that there is no uninsulated part of the lead projecting from the terminal.
- Use only leads up to 1.5 mm² maximum cross-section.



Connecting the GMC Ecoline 8304

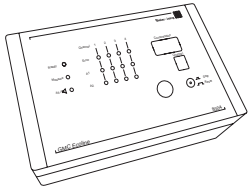

Option - DC Switch

For further switching tasks, four DC switches are available. Three different functions can be assigned to them when setting up the system. Please note the connection data: max. 32 VDC, max 200 mA.

- Option DC switch in parallel with relay:
 - K1 = Alarm 1 / pre-alarm
 - K2 = Alarm 2 / main alarm
 - K3 = horn
 - K4 = controller and sensor faults

- Option DC switch individual alarm 1:
 - K1 = Alarm 1 / pre-alarm measuring point GM1
 - K2 = Alarm 1 / pre-alarm measuring point GM2
 - K3 = Alarm 1 / pre-alarm measuring point GM3
 - K4 = Alarm 1 / pre-alarm measuring point GM4

- Option DC switch individual alarm 2:
 - K1 = Alarm 2 / main alarm measuring point GM1
 - K2 = Alarm 2 / main alarm measuring point GM2
 - K3 = Alarm 2 / main alarm measuring point GM3
 - K4 = Alarm 2 / main alarm measuring point GM4

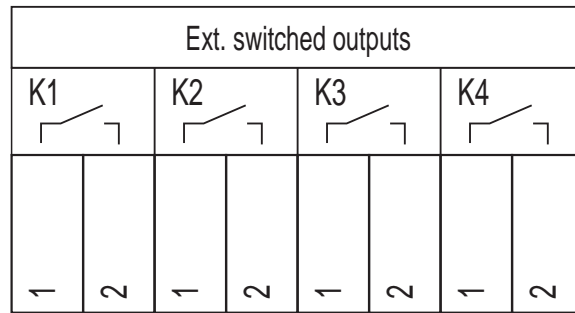

Contacts shown in alarm situation!

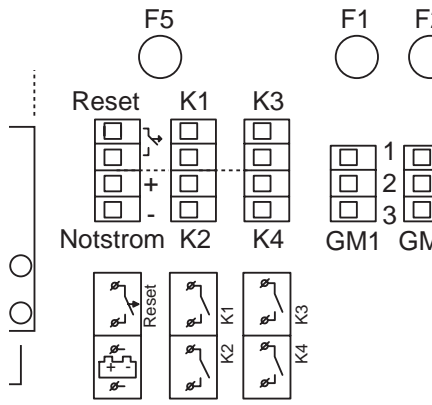

Instructions for connecting cables

- Passing cables through support diaphragms: Make a hole in the diaphragm with a Philips screwdriver. Pass an adequate length of cable through the hole. For optimum sealing, pull the cable back about 10 mm to form a collar which presses tightly round it.
- Remove about 8 mm of the insulation of the individual leads.
- Place the blade of a small screwdriver on the white release button of the appropriate terminal. Pressing lightly on the screwdriver will open the round terminal beside it.
- Push the stripped end of the correct lead into the terminal. Release pressure on the screwdriver to clamp the wire.
- Now pull gently on the lead to make sure it is securely clamped.
- Ensure that there is no uninsulated part of the lead projecting from the terminal.
- Use only leads up to 1.5 mm² maximum cross-section.



Connecting the GM Ecoline HC50

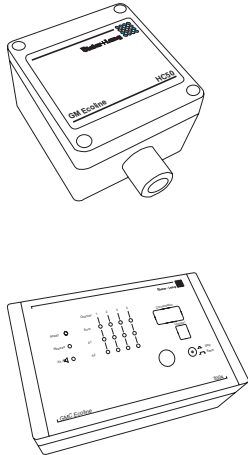

The required number of detectors can now be connected. Always begin with terminal GM1 and continue in numerical order to GM4.

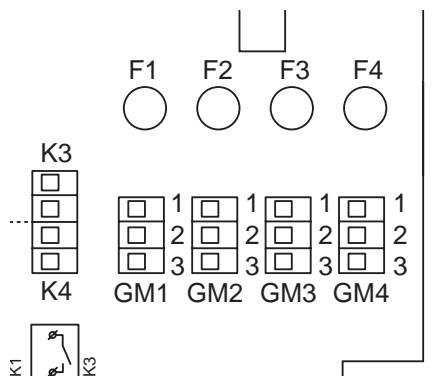
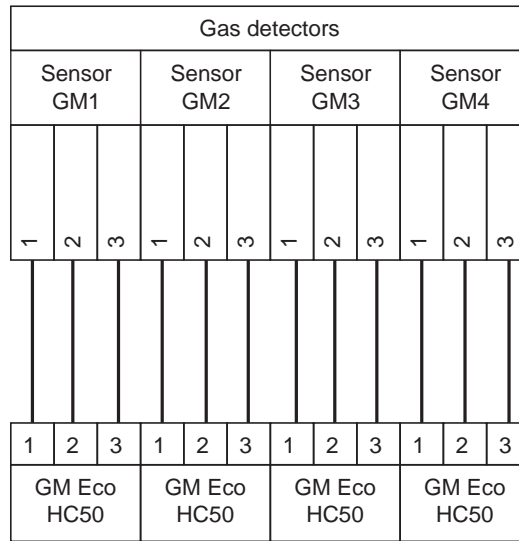

PCB for GMC Ecoline 8304

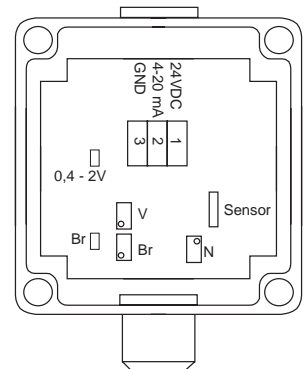

PCB for GM Eco HC50

Instructions for connecting cables

- Passing cables through support diaphragms: Make a hole in the diaphragm with a Philips screwdriver. Pass an adequate length of cable through the hole. For optimum sealing, pull the cable back about 10 mm to form a collar which presses tightly round it.
- Remove about 8 mm of the insulation of the individual leads.
- Place the blade of a small screwdriver on the white release button of the appropriate terminal. Pressing lightly on the screwdriver will open the round terminal beside it.
- Push the stripped end of the correct lead into the terminal. Release pressure on the screwdriver to clamp the wire.
- Now pull gently on the lead to make sure it is securely clamped.
- Ensure that there is no uninsulated part of the lead projecting from the terminal.
- Use only leads up to 1.5 mm² maximum cross-section.



Setting the GMC Ecoline 8304

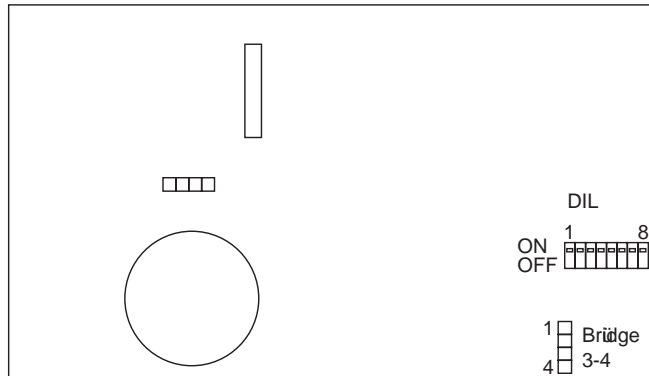
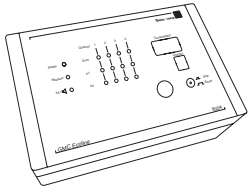

A range of different functions can be assigned to the GMC Ecoline 8304 controller. Set the DIL switches on the PCB in the housing cover according to your requirements:

Function	Switch positions							
	1	2	3	4	5	6	7	8
1 Measurement position	OFF	OFF						
2 Measurement positions	ON	OFF						
3 Measurement positions	OFF	ON						
4 Measurement positions	ON	ON						
Detection gas CH4			OFF					
Detection gas LPG			ON					
ALARM 1 non-latching				OFF				
ALARM 1 latching				ON				
ALARM 1 / 2 10/20					ON			
ALARM immediate						OFF		
ALARM after 30 seconds						ON		
DC switch parallel to relay							OFF	OFF
DC switch - individual alarm 1							ON	OFF
DC switch - individual alarm 2							OFF	ON

- **Measuring point**
Use switches 1 and 2 to enter the number of detectors connected.
- **Detection gas**
Use switch 3 to enter the gas that is to be monitored.
 - CH4: methane / natural gas
 - LPG: liquefied gas
- **Alarm 1 non-latching**
Alarm 1 latching
If required, the pre-alarm (Alarm 1) can also be equipped with an alarm memory (latching). This means that following an alarm, the alarm LEDs and the relay outputs assigned to them continue to indicate an alarm until it is acknowledged. Use switch 4 to set this function.
- **Alarm 1/2, 10/20**
The alarms are set to the following thresholds:
 - pre-alarm 10 %LEL, main alarm 20 %LEL
- **Immediate alarm, alarm after 30 seconds**
The alarm thresholds can be provided with a 30-second switch-on delay. Use switch 6 to set this function.
- **DC switches**
There are further integral DC switches for sending these signals to other systems in the building for further processing. These can be used for any of the following functions as required:
 - DC switch for collective alarm: pre-alarm, main alarm, horn, fault
 - DC switch for individual alarm 1: 4x individual pre-alarms
 - DC switch for individual alarm 2: 4x individual main alarms
 Use switches 7 and 8 to set these functions.



Final Steps in Installation of the GMC Ecoline 8304

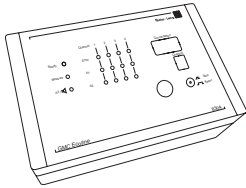

When the installation operations described above have been completed, carry out the following operations:

- To prevent the unintentional release of individual leads, bundle the circuits that belong together with the cable ties supplied. Take care that there is sufficient distance between the mains terminals and the switch contacts (where used) and the SELV circuits (detector connections, external reset).

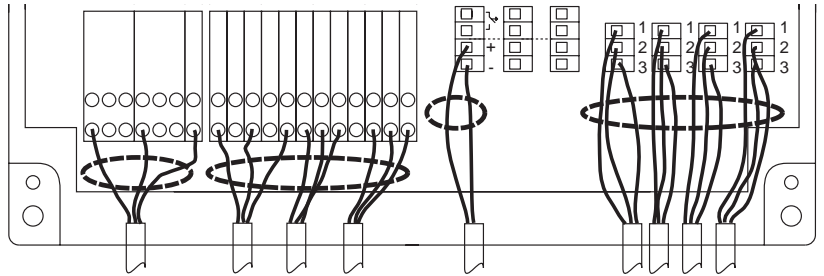

Example of bundling different circuits with cable ties

- Reconnect the ribbon cable from the cover tray with the electronics in the floor tray. Press the connector gently into place. Ensure that the polarity is correct. This is assured mechanically by a nose at the side. The latch lever on the short side of the connector must engage.
- Replace the insulation panel in the floor tray.
- Now fit the cover tray so that it is flush. Make sure the cover seal is correctly seated.
- Secure the cover with the four screws. The screws must not be over-tightened.
- Replace the two blue cover strips.

GM Ecoline HC50

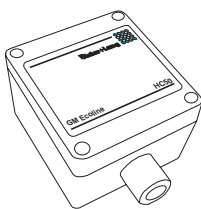

- Now fit the cover so that it is flush. Make sure the cover seal is correctly seated.
- Secure the cover with the four screws. The screws must not be over-tightened.



Commissioning

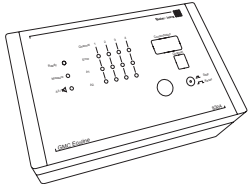

Warning! Only switch on the mains power supply again when installation work has been completed and proper operation is assured.

- Switch on the controller (power supply).
- Check the settings of the GMC Ecoline 8304 controller. The settings are displayed in ten steps. The displayed step is shown in the field „Channel“, and the related setting in the field „Concentration“.

Display step	Description	Value
9	Number of measuring points (sensor)	1 – 4
8	Detection gas	CH4 / LPG
7	Measurement range	100
6	Measurement unit	LEL
5	Alarm threshold 1	10
4	Alarm threshold 2	20
3	Alarm threshold 3	20
2	Switch 4	0 = Alarm 1 non-latching 1 = Alarm 1 latching
1	Switch 6	0 = Alarm - immediate 1 = Alarm - 30 s delay
0	Switches 7+ 8	0 = DC switch parallel to relay 1 = DC switch - individual alarm 1 2 = DC switch - individual alarm 2

- After 30 minutes warming-up time, check operation of the combination detector/controller by applying test gas. Proceed as described in the section „Adjustment“.



Never check that the system functions by using a gas lighter, a spray can, or inflammable vapours generated from paints or solvents.

General Instructions for Servicing, Adjustment and Care of the Gas Detection System



- Never check that the system functions by using a gas lighter, a spray can, or inflammable vapours generated from paints or solvents.
- The system must be adjusted at least once a year by a specialist authorised by Bieler + Lang.
- The working life of a thermal-effect sensor can be reduced by what are known as catalyst poisons. Such substances are compounds of sulphur, phosphorus, silicon, and lead. Corrosive substances, which may be formed by the reaction of fluorine and chlorine compounds, will reduce the anticipated working life of > 3 years.
- Clean the unit, on the outside only, with a damp cloth. Do not use any cleaning agent.

Adjusting the GM Ecoline HC50

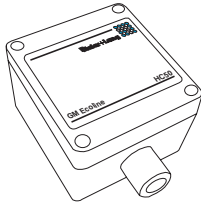

Electrostatically sensitive components. Contact with these parts could damage or destroy them. Avoid touching them! Grasp PCBs only on their edges. Before starting work, ensure that you are electrostatically discharged by touching earthed metal parts.

Accessories required

- Voltmeter with leads for measuring
 - Test gas set consisting of:
 - 1 x Minican with test gas:
 - For natural gas:
1.76 vol% (40 % LEL) methane in synthetic air
 - For liquefied gas / LPG:
0.68 vol% (40 % LEL) propane in synthetic air
 - 1 x Minican synthetic air
 - pressure regulator with control valve and flow meter
 - Test gas cap
- Screwdriver for adjusting

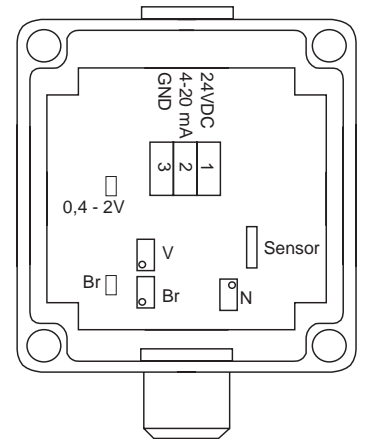
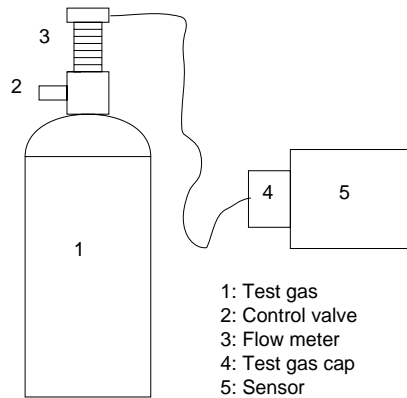

Adjustment

- Remove the cover from the housing
- Fit the test gas cap to the sensor.
- Apply test gas at a flow rate of 10 - 20 l/h (2nd. division of scale).

Zero setting

- Apply zero gas (synthetic air) if the environment contains the gas to be detected.
- Connect a voltmeter to the „Br“ test sockets.
- Wait until the „Br“ voltage reading has stabilised.
- Adjust the „Br“ potentiometer until the reading is 0.0 mVDC.
- Connect a voltmeter to the „0.4-2V“ test sockets.
- Wait until the „0.4-2V“ voltage reading has stabilised.
- Adjust the „N“ potentiometer until the reading is 0.40 VDC (=4 mA).

Amplification

- Apply test gas in a known concentration:
 - For natural gas:
1.76 vol% (40 % LEL) methane in synthetic air
 - For liquefied gas / LPG:
0.68 vol% (40 % LEL) propane in synthetic air
- Wait until the „0.4-2V“ voltage reading has stabilised.
- Adjust the „V“ potentiometer until the reading is 1.04 VDC (=10.4 mA).
- The GMC Ecoline 8304 must show a reading of 40% LEL for the appropriate measurement channel, alarm stages 1 and 2 must be triggered, and the built-in buzzer must sound.
- Connect a voltmeter to the „Br“ test sockets.
- If the measurement signal is less than 0.02 VDC (20 mVDC), the sensor must be replaced.

Final measures

- Disconnect the test gas and measuring leads.
- Refit the cover to the housing.
- Prepare a test report.



**Replacing
GM Ecoline HC50 Sensors**

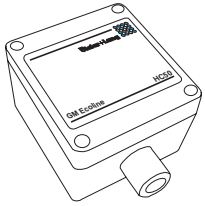

Warning! Sensors should only be replaced by a qualified electrician.



Electrostatically sensitive components. Contact with these parts could damage or destroy them. Avoid touching them! Grasp PCBs only on their edges. Before starting work, ensure that you are electrostatically discharged by touching earthed metal parts.

If you find, during adjustment, that the sensitivity of a sensor has deteriorated, or if there has been an increase in the number of false alarms due to changes in the ambient or operating conditions, the sensor element must be replaced.

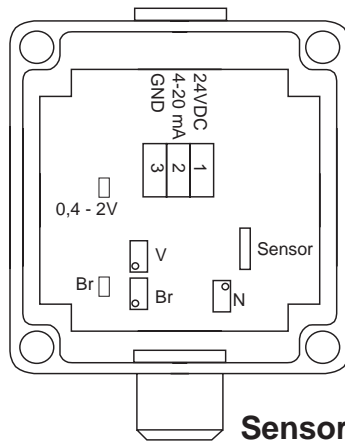

Sensor

- Turn off the power supply to the GMC Ecoline 8304 controller at the contact breaker in the supply line.
- Open the housing of the detector.
- Disconnect the „Sensor“ lead from the PCB.
- Turn the sensor anti-clockwise to remove it.
- Screw in the new sensor hand tight. Make sure the seal is correctly seated.
- Reconnect the „Sensor“ lead to the PCB. Make sure the polarity of the connections is correct.
- Turn on the power supply to the GMC Ecoline 8304 controller again.



After replacing the sensor, the detector must be readjusted.



Overview of Fault Messages

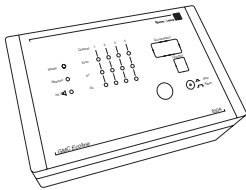

Message	Meaning	Possible causes
Ready LED: off	No power supply	The circuit breaker has tripped out. If an emergency power supply is connected: fuse F5 has blown; the battery is flat.
Error LED: on	Faulty detector signal	Reading < -6 % LEL Reading > 106 % LEL Broken wire to detector Short circuit in lead to detector A fuse F1 - F4 has failed.



Warning! Repairs should only be carried out by a qualified electrician.



After a repair, the entire gas detection system must be checked. To do this, follow the instructions in the section „Commissioning“.

Replacement Parts

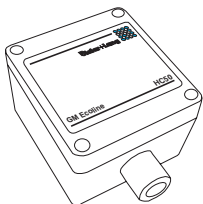
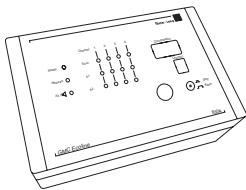

- **GMC Ecoline 8304:**
 - Fuse F1 - F4
100 mAT, Type TR5-T
Order number TN 12.070969
 - Fuse F5
1 AT, Type TR5-T
Order number TN 12.070438
- **GM Ecoline HC50**
 - Replacement sensor
Order number TN 12.101026

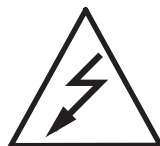

Warning! Repairs should only be carried out by a qualified electrician.



After a repair, the entire gas detection system must be checked. To do this, follow the instructions in the section „Commissioning“.

Cleaning

Clean the unit, on the outside only, with a damp cloth.
Do not use any cleaning agent.



Technical Data

GMC Ecoline 8304

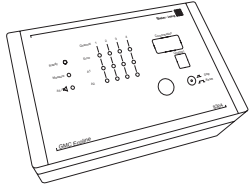

Number of detectors	Max. 4 measuring points
Detector input	4 x 4-20 mA
External reset	Yes
Outputs	Potential-free changeover contacts (230 VAC, 4A) and photo-MOS relay (32 VDC, 200 mA) - collective alarm, Alarm 1 - collective alarm, Alarm 2 - collective alarm, Alarm 3 (horn) - device fault
Alarm device	Built-in alarm buzzer 85dB(A)
Display elements	- Display for concentration - Display for channel number - LEDs for Alarm 1, 2, Fault, Ready, Measuring
Power supply	100 - 240 VAC, 47 - 63 Hz, 20W
Emergency power supply	1x 24VDC emergency power input
Distribution terminals	6 each for N, PE; 3 for L
Temperature range	-10°C to +40°C
Humidity	10 – 95% RH (non-condensing)
Air pressure	800 – 1200 hPa
Environment	- Not for use more than 2000m above sea level - Not for use out of doors - Protect from direct sunlight
Storage conditions	-10°C to +70°C 10 – 95% RH (non-condensing)
Degree of protection	IP44
Housing	Plastic housing (240x190x90 mm)
Weight	1300 g
Expected working life	Typically > 8 years
Connections	- Mains connection: cable gland, sealing range 7 - 14 mm - Cable entry (detectors, switched outputs): double-diaphragm glands, sealing range 5 – 9mm
Functional assessment	EN 50194 Electrical apparatus for the detection of combustible gases in domestic premises. TÜV Süd Automotive GmbH, Bericht BA68851T
Electrical safety	EN 60335-1 Household and similar electrical appliances - Safety
EMC requirements	EN 50270 (Type 1) EN 61000-6-3

GM Ecoline HC50

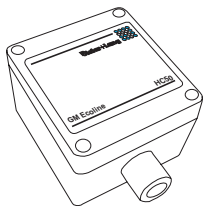

Measurement principle	Thermal-effect sensor
Measurement range	0-100% LEL
Detection gases	Methane, propane, butane
Visual display	LED illuminates when 4-20mA is active
Output	4-20mA
Humidity	10 – 95% RH
Air pressure	800 – 1100 hPa
Environment	- Not for use more than 2000m above sea level - Not for use out of doors - Protect from direct sunlight
Storage conditions	-10°C to +70°C 10 – 95% RH (non-condensing)
Degree of protection	IP44
Housing	Plastic housing (110x56x81 mm)
Expected working life	- Electronics: typically > 8 years - Sensor (measuring element): typically >3 years ¹⁾
Weight	170 g
Connections	Cable gland double-diaphragm glands, sealing range 5 – 9mm
Supply voltage	SELV nom. 24VDC, min.18VDC, max. 28VDC
Functional assessment	EN 50194: Electrical apparatus for the detection of combustible gases in domestic premises. TÜV Süd Automotive GmbH, Bericht BA68851T

1) The working life of a thermal-effect sensor can be reduced by what are known as catalyst poisons. Such substances are compounds of sulphur, phosphorus, silicon, and lead. Corrosive substances, which may be formed by the reaction of fluorine and chlorine compounds, will reduce the anticipated working life of > 3 years.

Mechanical Data

GMC Ecoline 8304

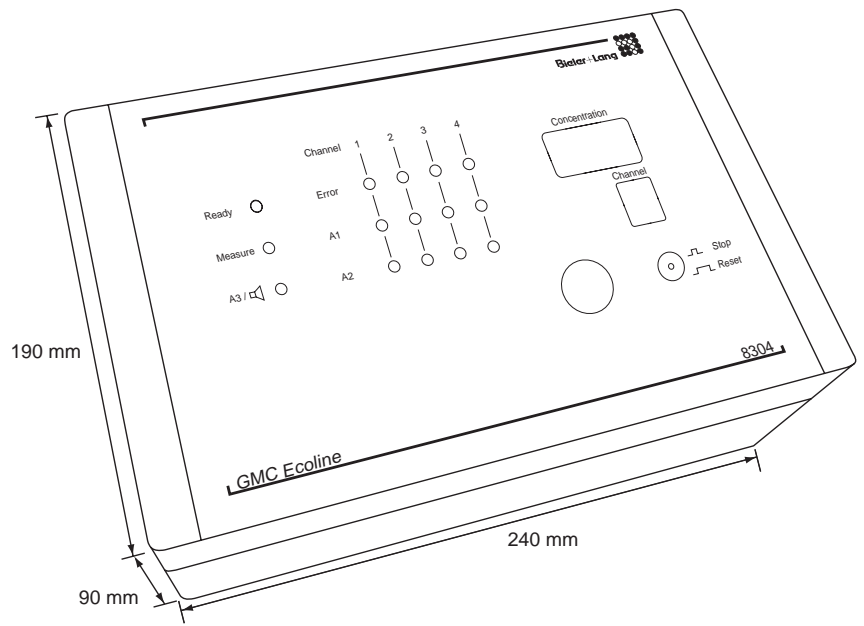

GM Ecoline HC50

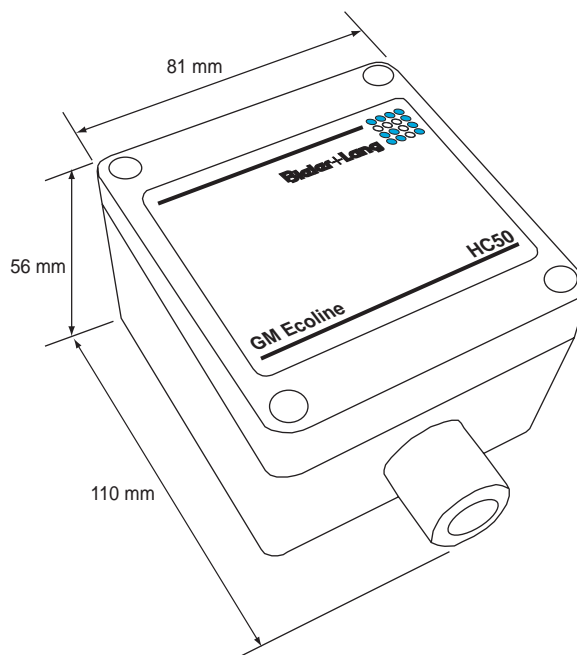



**Appendix
Adjustment Report for
GM Ecoline HC50**

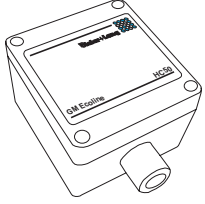

Date	Channel / Detector	Reading 0,4- 2V	Calgas	Comment/ Signature
	1			
	2			
	3			
	4			
	1			
	2			
	3			
	4			
	1			
	2			
	3			
	4			
	1			
	2			
	3			
	4			
	1			
	2			
	3			
	4			

**Accessories**

- Gas extractor
Order number TN 12.100732
 - Test gas cap PK 8
Order number TN 12.100790
 - Measurement cable
Order number TN 12.100403
 - Test gas: methane 1.78 vol.% (40% LEL)
Order number TN 12.080208
 - Test gas: propane 0.68 vol.% (40% LEL)
Order number TN 12.080211
 - Test gas: synthetic air
Order number TN 12.080214
 - Screwdriver for adjusting
Order number TN 12.076788

 - Warning lights, warning signs
 - Signal horns
-

Guarantee

For all deliveries, the general conditions of supply and delivery for products and services of the electrical industry apply.

With the exception of parts subject to wear, e.g. sensors, the guarantee on all parts is two years from the delivery date or, if commissioning is carried out by our customer service or local representative, from the date on which they were first put into service.

Please note that, if the equipment is not correctly installed, operated and serviced, the right of complaint about material defects is forfeited. It is a prerequisite that the sensor is not installed in a contaminated environment. In particular, it is not possible to make an estimate of the expected working life of the sensor under different (reactive) environmental conditions such as humidity, or severe heating, or under the influence of injurious gases (for example sulphur, silicon or lead compounds etc.).

For claims for material defects, the period of the statute of limitations is 12 months. The guarantee period is not the same as the anticipated working life under permitted environmental conditions while observing the servicing and checking intervals specified by the manufacturer.

Bieler + Lang GmbH
Gas Detection and Warning Systems

Postfach 1129, D-77842 Achern
Oberkirchstr. 19-21, D-77855 Achern

Telephone +49 (0) 78 41 69 37 - 0
Telefax +49 (0) 78 41 69 37 - 99
E-mail info@bieler-lang.de

Internet: www.bieler-lang.de
