

**ExDetector
HC-200**

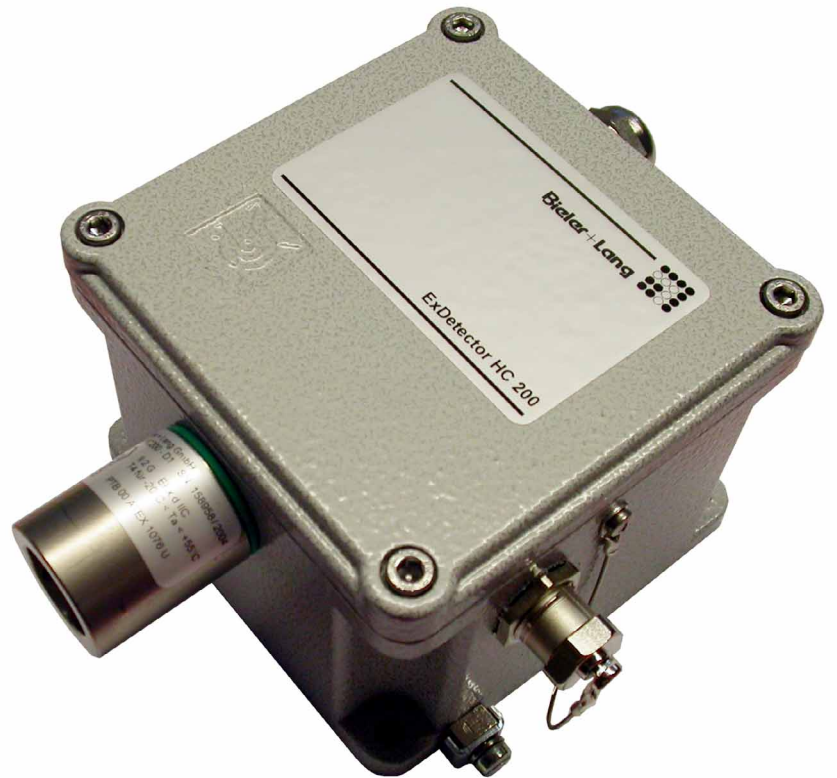

Data Sheet

Gas Detection and Warning Systems

Installation / Set-up

The gas detector ExDetector HC 200 has the following functions:

- Measurement of the current gas concentration
- Monitoring and warning of the presence of this gas
- Initiating protective measures:
 - Technical: countering a further increase in concentration (fans, switching off....)
 - Organisational: visual and acoustic messages and warnings.

Product Features

- Monitoring combustible gases and vapours
- Measurement range: 0 ... 100 % LEL
- Measurement principle: catalytic combustion (thermal effect)
- Linear measurement signal 4 ... 20 mA
- Integral switched outputs for:
 - Alarm 1 (pre-alarm)
 - Alarm 2 (main alarm)
 - Sensor defect
- One-man calibration (using optional calibrator)
- Intended for use in Ex-zone 2

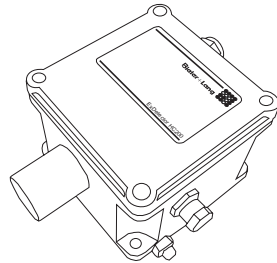

How It Works

The detector electronics regulate the operating parameter (heating voltage) of the sensor. The sensor consists of an active and an inactive element. The inactive sensor element is connected to the active element in a Wheatstone bridge, and compensates for ambient influences, such as temperature variations. As soon as a combustible gas reaches the active sensor, combustion of the gas to be measured takes place. The heat of reaction changes the electrical resistance and thus the signal from the bridge circuit. These small voltage signals are processed and converted to a 4 ... 20 mA signal.

The ExDetector HC200 can be programmed for either of two different types of operation:

- **Standalone**
Integral alarm evaluation is switched on. Two alarm stages with cut-off hysteresis can be programmed. Alarm stage 1 is intended as a pre-alarm and does not incorporate normally-closed contacts with memory effect. Alarm stage 2 (main alarm) switches a pair of normally-closed contacts with memory effect. When the signal falls below the alarm threshold, the alarm remains on and must be acknowledged via the reset input. An error-message contact signals malfunctions and exceeding the measurement range. In addition, the reading is transmitted as a 4 ... 20 mA signal for further processing.
- **Transmitter CL**
If the alarm evaluation function is not required, the probe can be operated with the integral option CL. In this case, the probe transmits the measured gas concentration as a 4 ... 20 mA signal for further processing in an alarm controller; the alarm switching contacts are not active.

Using the optional calibrator, which is also explosion-protected, operating parameters can be programmed and the probe element adjusted. Thus, operation and maintenance can also be carried out in hazard zones.

Block Diagram

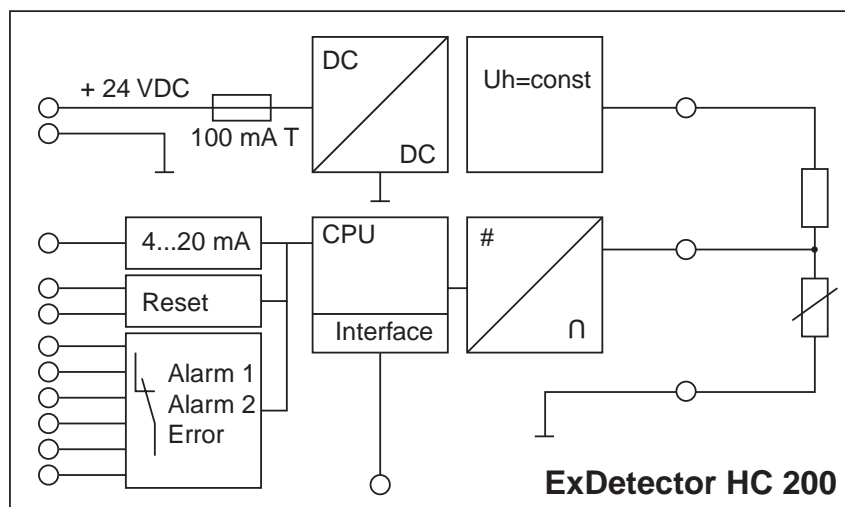

**Technical Data
(Gases)**

	ExDetector HC200
ATEX marking	II 3(2) G Ex nA de [ib] IIC T4 PTB 05 ATEX 1047
Field of application	Ex-zone 2
Category	3
Equipment group	II
Atmosphere	G
Installation	Wall-mounting
Detection gases	Combustible gases / vapours 1)
Measurement range:	0 ... 100 % LEL
Measurement principle:	Catalytic combustion (thermal effect)
Response time (T90)	Dependant on detection gas (typically < 30 sec)
Max. flow speed	6 m/sec
Temperature range	-20 °C ... +55 °C
Air pressure range	800 ... 1100 hPa
Humidity range	20 ... 90 % RH
Storage conditions	Temperature: -25 °C to 60 °C Air pressure: 800 hPa to 1100 hPa Humidity: 20% RH to 90% RH

1) The working life of a thermal-effect sensor is limited by what are known as catalyst poisons. Such substances are compounds of sulphur, phosphorus, silicon, and lead. Corrosive substances, which may be formed by the reaction of fluorine and chlorine compounds at the measuring cell, will reduce the anticipated working life of > 3 years.



**Technical Data
(Installation)**

	ExDetector HC200
Field interface	4 ... 20 mA Safety-related maximum voltage Um=250V
Supply voltage (detector terminals)	18 ... 28 VDC SELV / PELV Integral fuse 100 mA Safety-related maximum voltage Um=250V
Calibration interface	Ex-protection class, intrinsically-safe EEx ib IIC; only for connection to a certified intrinsically-safe circuit: Maximum values: Uj = 13.8 V; Pi = 432 mW Li and Ci negligibly small
Switch contacts	- Alarm 1 (pre-alarm) - Alarm 2 (main alarm, latching) - Fault all are NC contacts (fail-safe), max. 28 VDC SELV/PELV, with integral fuse (200 mA)
Reset input	18 ... 28 VDC, potential-free
Max. cable length	200 m
Suitable controllers	Gasmesscomputer 8022, GMC 8022E, GMC 8364
Electrical safety of equipment	II 3(2) G Ex nA de [ib] IIC T4 -20°C < Ta < +55°C PTB 05 ATEX 1047

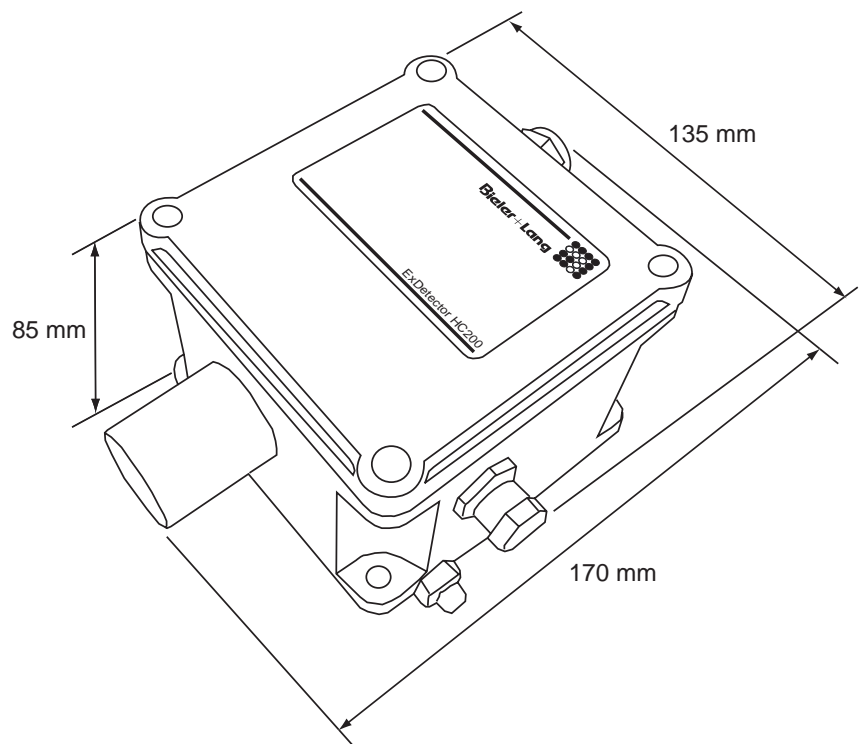

Mechanical Data

	ExDetector B 200
Degree of protection (housing)	IP54
Housing material	Sensor: stainless steel Housing: aluminium
Weight	ca. 800 g
Cable gland	1) One cable gland for cable diameter 6 ... 10 mm 2) One plug M16
Connection terminals	0.5 ... 2.5 mm ² (w/o terminal sleeves) 0.5 ... 1.5 mm ² (with terminal sleeves)



**Certificates**

Directive 94/9/EC Equipment for use in potentially-explosive atmospheres:

- Electrical safety of equipment
II 3(2) G
Ex nA de [ib] IIC T4
-20°C < Ta < +55°C
PTB 05 ATEX 1047
-

Safety

For its intended use in Ex-zone 2, compliance with the following standards, ensures the highest levels of safety and reliability:

- EMC Directive 2004/108/EC
 - ATEX Directive 94/9/EC
-

Accessories

- Test-gas set
 - Calibration gases
 - Calibrator Calibrationbox-i
-

Service

Everything from a single supplier - from system design to installation of your new gas warning system. The comprehensive coverage of our sales and service network ensures this. Ask us about regional representatives in your area. And after purchase our service technicians are available to help and advise.

Bieler + Lang GmbH
Gas Detection and Warning Systems

Postfach 1129, D-77842 Achern
Oberkirchstr. 19-21, D-77855 Achern

Telephone +49 (0) 78 41 69 37 - 0
Telefax +49 (0) 78 41 69 37 - 99
E-mail info@bieler-lang.de

Internet www.bieler-lang.de

Technical status: 04/2010

We reserve the right to make technical changes.
